

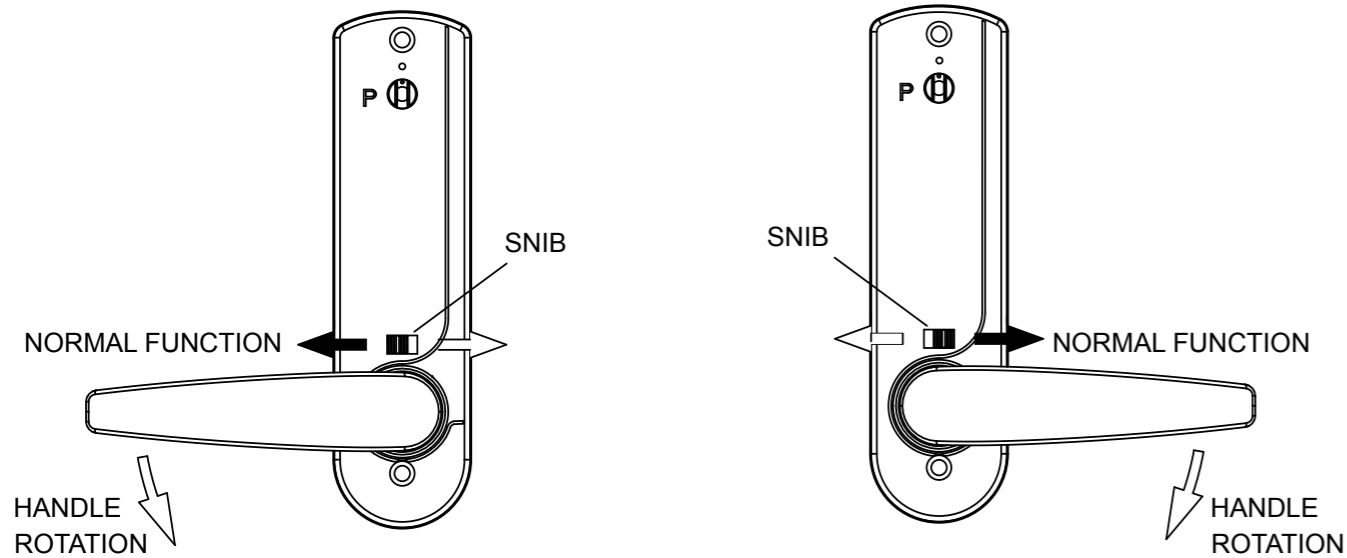

Digital Lock Set SL7100 Series

Digital Lock Set - Holdback Function

- * To activate Holdback function. Pull inside handle down to 6 o'clock position to completely withdraw the latch bolt.
- * Hold the handle in this position and slide snib as shown to retain handle and set Holdback function.



Digital Lock Set-Changing the Code Number

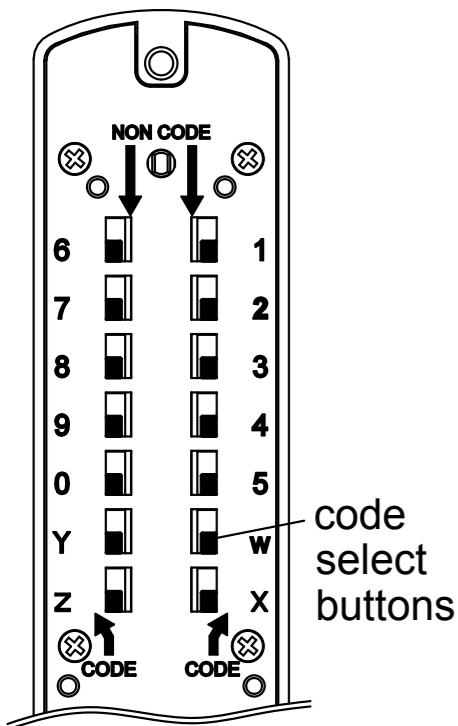

- 1) The digital lock is supplied with factory set codes: C13579
- 2) Depress the code select button and slide the selector from "NON CODE" to "CODE" position and the active number is selected as shown by the RED indicator.
- 3) Any numbers not required to be part of the active code should have the code selectors parked in the "NON CODE" position.
- 4) The "CLEAR" button MUST always be used as the first digit of a code.
- 5) For best security the code number selected should contain 4 or 5 digits
- 6) Check that the new code works before installation.

NOTE: THE CODE MAY BE ENTERED IN ANY SEQUENCE, I.E. C13579 MAY BE ENTERED AS C19735 OR ANY OTHER SEQUENCE OF THOSE NUMBERS.

Q25079 0312-2



Digital Lock Set SL7100 Series

Components

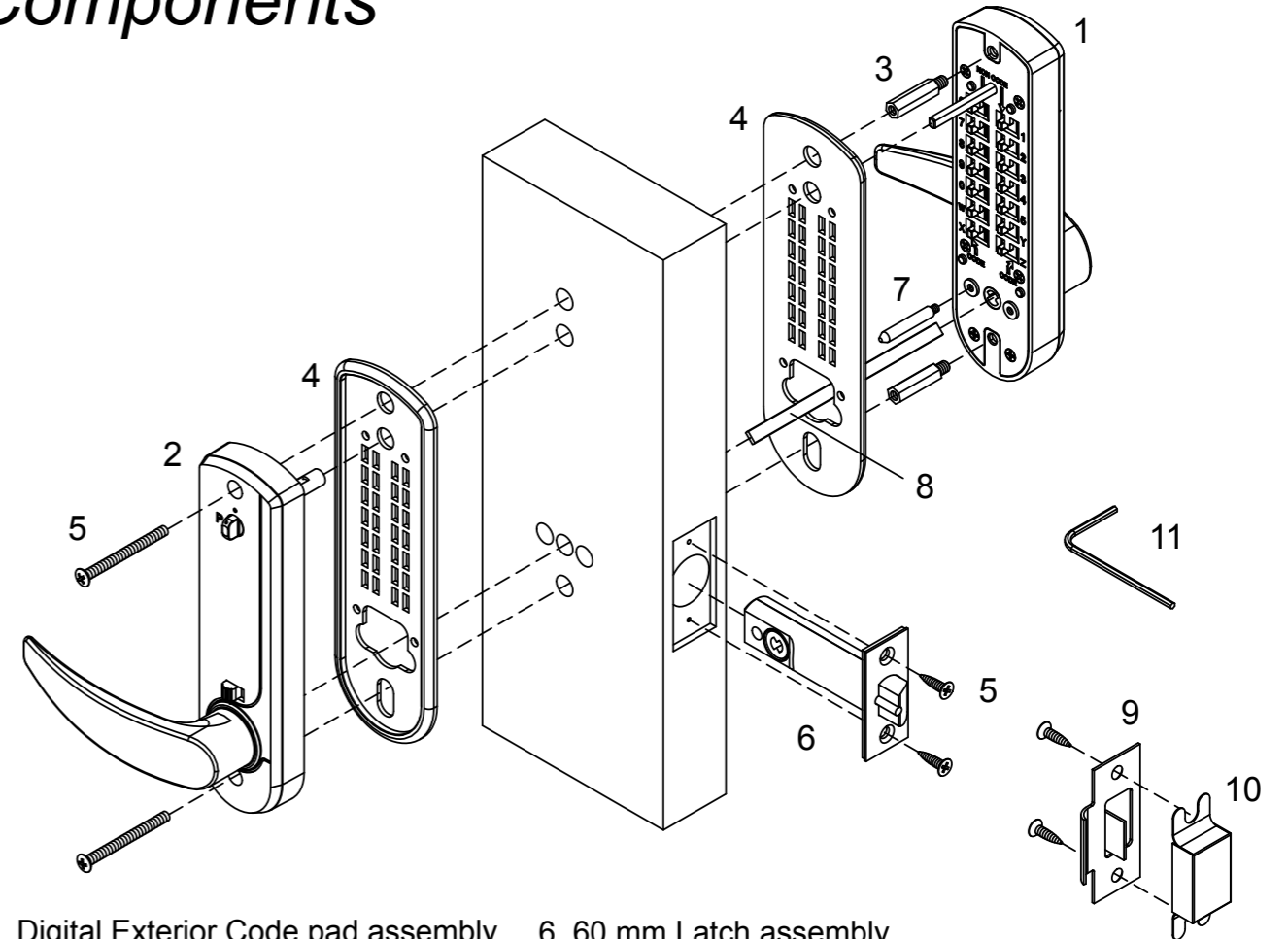

- | | |
|---|--------------------------------|
| 1. Digital Exterior Code pad assembly | 6. 60 mm Latch assembly |
| 2. Digital Interior handle assembly | 7. Latch Assembly support post |
| 3. Hex Screw Post 25mm x 2 | 8. Spindle x 3 |
| 4. Neoprene seals x 2 | 9. Strike plate |
| 5. All fixings - 4 code pad fixing screws,
4 latch & strike screws | 10. Strike box |
| | 11. Allen key |
| | 12. Instructions and template |

Installation Instructions 1) Check the Handing of Your Door

SPECIAL NOTES:

Before commencing installation check that all parts are working correctly.

* Digital Exterior and Interior Code Pad Assembly: Enter the factory set code C13579, handle in both directions. The handle should turn and return freely under it's own return spring.

* Digital Deadlatch Assembly: Check that spring latch and spindle hub move freely.

If you need to change the code you should change it now and test before fitting. - see the Code Change instructions

NOTE: FACTORY HANDING - ALL LOCKSET ARE SET TO SUIT RIGHT HAND DOORS

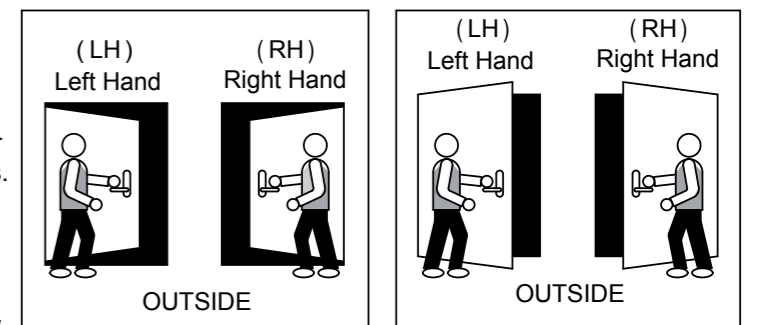

Viewed from the outside, your door is right handed if the hinges are on the right.

2) Apply the Template

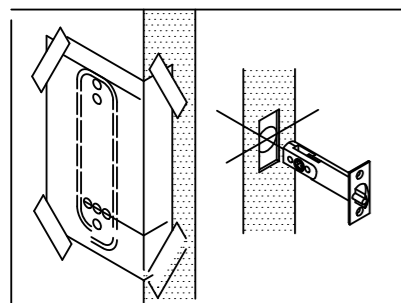

- Select the desired position on the door. Fold the template on the dotted 60mm backset line to suit the deadlatch assembly supplied. Tape the template to the door.
- * Mark and drill six 10mm holes as shown on the template.
 - * Mark the central point on the "centre line of latch" on the edge of the door and drill a 25mm hole to a depth of 85mm.
 - * Insert the latch into the latch holes and mark around the face plate.
 - * Remove the latch and cut a 3mm rebate so that the face plate fits flush with the edge of the door.
 - * Fit the latch assembly with 2 wood screws. (Ensure that the bevelled face of the latchbolt faces the door frame)

3) Handing the Digital Exterior Code Pad Assembly

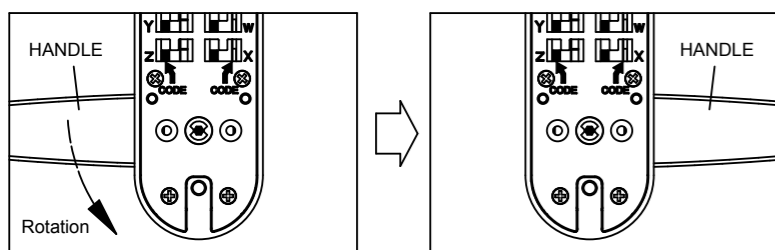

Apply strength to rotate the handle to the desired direction.

IMPORTANT: In order to change the left and right hand of the lock handles correctly, the lock must be mounted on the door.

4) Handing the Digital Interior Handle Assembly

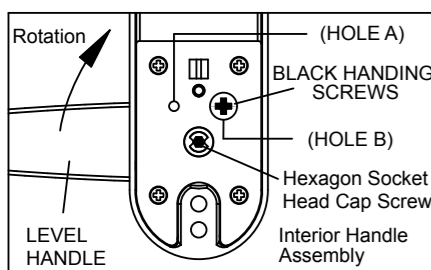

- Hole A for left hand hung door and Hole B for right hand hung door.
- To change for a left hand door:
- * Remove BLACK handling screw from hole A and relocate it in hole B.
- To change lever handle to suit a left hand :
- * Loosen the Hexagon Socket

5) Fit Latch Support Post

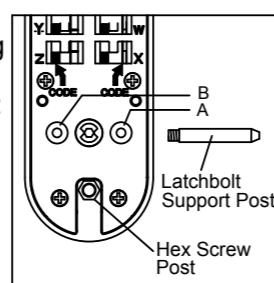

Fit the Latch Assembly Support Post in the back of the Digital Code Pad Assembly. Hole A for left hand hung door and Hole B for right hand hung door.

Fit Hex screw post top and bottom of external keypad.

Head Cap Screw located at the bottom of the spindle hub and rotate the lever handle from right to left.

* Tightening the Hexagon Socket Head Cap Screw and make sure the lever handle is horizontal.

Check correct lever handle function by turning handle from horizontal position through 90° without resistance

6) Positioning the Spindles

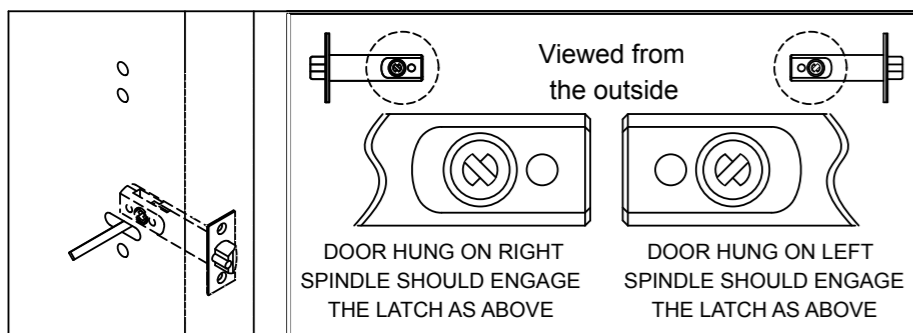

- Three spindles are provided. Select the spindle length to suit the door thickness.
- * For door thicknesses less than 35mm use the shorter spindle (76mm). For door thicknesses of 35-50mm use the longer spindle (86mm) or (100mm).
 - * Position spindle centrally through the latch hub to suit door handing as shown.

7) Mounting the Lock

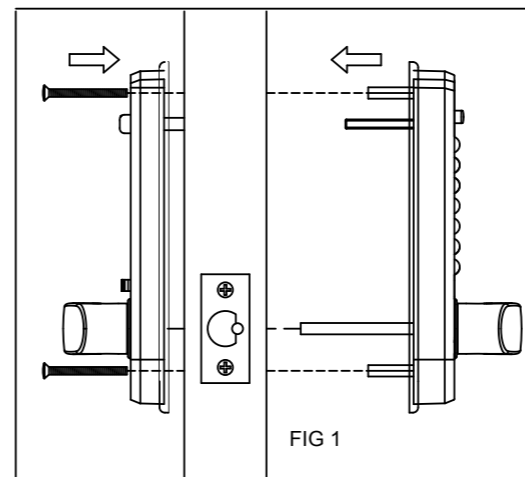

- Select the fixing screws to suit the door thickness.
- * For door thicknesses less than 48mm use the shorter fixing screws (36mm).
 - * Fit the neoprene seals to both the Exterior Code Pad and Interior Handle Assemblies.
 - * Hold the Exterior Code Pad Assembly onto the door with the spindle in position and ensuring that the latch support post engages the hole in the latch assembly.
 - * Locate the Interior Handle Assembly on the inside of the door engaging the spindle in the handle hub.
 - * Screw both sides together with fixing screws top and bottom. (FIG 1)
 - * Before tightening of fixing screws make sure the lock is vertical. Test the mechanism to ensure that the lock functions correctly and moves easily.
- NOTE:** DO NOT overtighten the fixing screws-this may cause distortion and lead to poor operation.
- CHECK THAT THE CODE WORKS TO AVOID A LOCKOUT BEFORE CLOSING THE DOOR.**

8) Fitting the Strike Plate

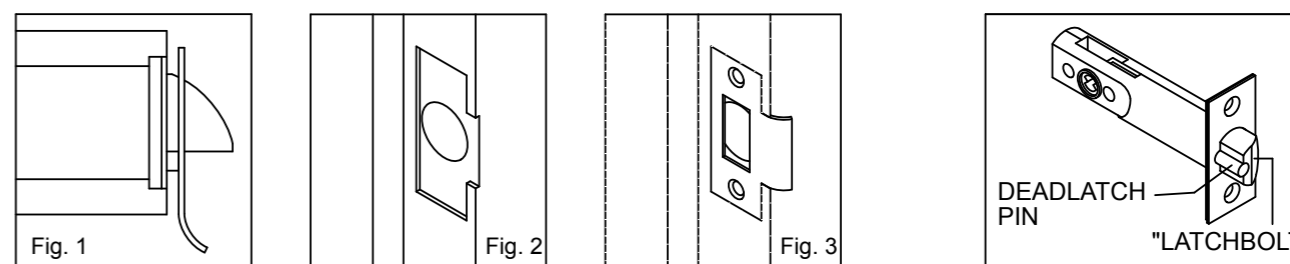

- * Close the door against the door frame and transfer the centre of the latchbolt onto the jamb.
- * Position the strike plate on the door so that it fits against the flat of the latchbolt, with deadlatch pin depressed (Fig. 1).
- * Close the door and mark the position of the strike plate on the door jamb.
- * Using the strike plate as a template, align it with the position marks in the jamb and mark the inner and outer edges of the strike plate on the jamb. (Fig 2).
- * Cut a 1mm deep rebate so that the strike plate fits flush with door jamb (Fig 2).
- * Drill and chisel out the latchbolt hole to accommodate the latch bolt strike box (Fig 3).
- * Fit strike plate and strike box using only one wood screw at first to ensure that it is positioned accurately.
- * The latchbolt and not the deadlatch pin should enter the strike plate aperture freely and engage without excessive play.
- * When correctly positioned secure with the second wood screw and check lock set for smooth operation.

Digital Lock Set - Passage Mode Function

Passage Function - where fitted

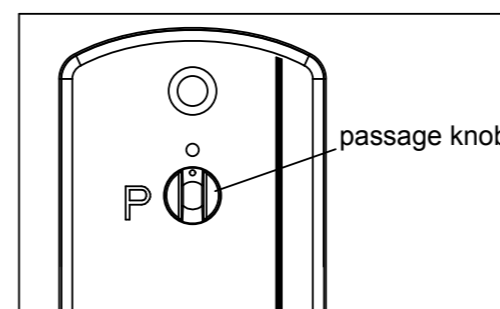

TO SET PASSAGE MODE - FREE ACCESS AND EGRESS.

- * Enter correct codes turn the handle of Digital Exterior Code Pad Assembly to 6 o'clock position and hold the handle in downward position.
- * Turn the passage knob of Digital Interior Handle Assembly from 12 o'clock to 9 o'clock "P" position. Release the handle and "Passage Mode" is set. Then you do not need a code and you can open the door.

TO SET CANCEL PASSAGE MODE -

- * Turn handle of Digital Exterior Code Pad Assembly to the 6 o'clock position, followed by a passage knob of Digital Interior Handle Assembly to the 12 o'clock position.